

**Jimveo**

# USER MANUAL

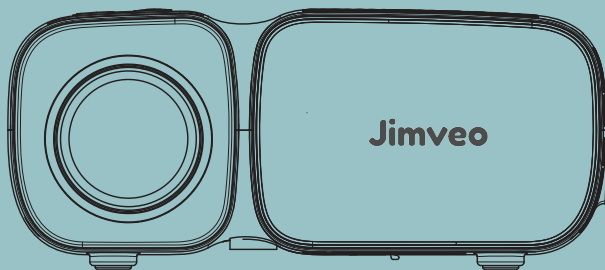

## C11 VIDEO PROJECTOR

WORLD BEAMS WITH JIMVEO

0828

# Content

CONTACT US .....	01
TROUBLE SHOOTING .....	02
PACKING LIST .....	05
FUNCTION OVERVIEW .....	06
QUICK START .....	10
INPUT SOURCE .....	11
DVD CONNECTION .....	12
MENU AND SETTING .....	13
WIRELESS PROJECTION WITH PHONES AND LAPTOPS .....	17
INSTALLATION .....	24
SPECIFICATION .....	27

We are constantly optimizing and upgrading our products, the pictures and descriptions in the manual are for reference only and may differ from the actual product, please refer to the actual product. You can get the latest version through online upgrade. Thank you for your understanding.

If you don't receive a reply in 48h, it may be that our emails are folded to your spam mailbox, please check your spam mailbox or send us an email again.Thanks!

## CONTACT US

Thank you very much for Supporting JIMVEO! Hope our products and services can bring you a pleasant journey of audio-visual enjoyment.

JIMVEO promises a **3-year warranty and lifetime technical** Support, please do not worry when encountering any problems. **Any buyer with any questions who comes to contact us will have our promise to get a satisfactory solution + an Extra 6 Month Warranty to thanks for your Support!**

In fact, many problems can be easily solved by adjusting the device settings, such as lack of signal and sound, failed Bluetooth and WiFi connection, dark spots, choppy animation, etc. We promise all the projectors have been 100% carefully checked and packaged before shipping.

**By the way, we are racking our brains to develop a new projector. If you have any ideas about the projector, such as user experience, parameters, features, appearance and colors, we warmly invite you to tell us in detail. We value all voices, and you won't imagine how much we look forward to your ideas. Once your idea is adopted, as a thank you, I will apply to send one to you for free as the first tester when the new product is developed.**

Scan QR code below, start chatting with us! ! !



Instagram

Scan this code, learn how to operate the projector visually on YouTube!



YouTube

EU:Support@jimveo.com



Facebook: JIMVEO



Youtube: JIMVEO



(If you don't receive a reply, maybe our emails went into your spam mailbox, please check the junk mailbox or send us an email again. Thanks!)

## TROUBLE SHOOTING

Our high-qualified customer services team is waiting to hear from you and answer any of your questions 24 hours a day and 7 days a week. We are happy to receive your message about the problems you met so that we can help you to get out of the trouble. You can contact us through email.



[Support@jimveo.com](mailto:Support@jimveo.com)

**Q:** Where can I find the instructional videos on how to set up the projector?

**A:** We have prepared detailed operation videos on YouTube, which contains almost every step of operating the projector, like wifi connection, wired connection and so on. Just search "[Jimveo](#)" on YouTube and you will find them

**Q:** I adjust the focus ring but the picture is still blurry, what should do?

**A:** ①The recommended projection distance is 5.2ft-9.5ft(1.6m-3m).  
②Please adjust your projection distance accordingly and adjust the focus ring until you reach the best image quality.

**Q:** I can't play Netflix video on the projector, why?

**A:** There are quite a few video platforms like Netflix, Disney+ and Hulu are under HDCP copyright protection, and thus do not Support being displayed on a projector, this is the same situation for all projectors. You would need a tv stick to enjoy these video platforms.

**Q:** I contacted the customer service but haven't received any reply. What should I do?

**A :** You have our promise that our professional customer service team will reply to all your messages within 24 hours. If you have not received our reply after 24 hours, then maybe our email or your email has been blocked. Please check your spam email box or resend your letter to us.

Q: I connect the projector and my phone with same wifi, but I can't find the projector's name when I want to do screen mirroring.

A: ①Please make sure your wifi is in good running speed.  
②You can try to reset wifi or restart the projector, or restore factory default. You can find the operation videos on our "jimveo" channel on YouTube.  
③If you tried the above ways and still can't solve the problem, please send email to our Support team along with your order number, we will find solutions for you.

Q: I received the projector but it has no remote control. Where can I get a new one?

A: If the product you receive is missing any accessories, please let us know what accessory do you miss. We will send them to you as soon as possible. Please email us via:

 [Support@jimveo.com](mailto:Support@jimveo.com)

Q: The projector worked for ten minutes and suddenly shut down. What should I do?

A: We promise that our projector has been carefully checked before shipping. However the long time and distance shipping may cause damage to the projector. If your projector can not work, please contact us and we will offer you satisfactory solution.

Q: What should I do if there are black spots on my projection screen?

A: ①Please believe in the quality of our projector. This spot may be caused by dust in the lens due to collision during transportation.

②You can use a screwdriver to open the lid under the projector. Then please use a hair dryer to blow the inner screen of the projector with a hairdryer. If this operation does not solve the problem, please open the bottom cover and try to wipe the inner screen of the projector with a clean cotton swab. You can find the operation videos on our "Jimveo" channel on YouTube.

③If you can not solve your problem, please feel free to email us via:

 [Support@jimveo.com](mailto:Support@jimveo.com)

We'll give you a satisfactory solution.

Q: There appears big brown spots in the projector's screen after I use the it for about 3 months. Can I have this problem solved?

A: ①This phenomenon is often caused by overheating of the projector. Please make sure the projector's ventilation inlet and outlet uncovered to ensure that the projector can dissipate heat properly.

②Please turn off the projector, wait for a few hours until it totally cooled off. And then restart the projector.

③If you can not solve your problem, please feel free to emial us. Our projector offers **3-year warranty**. We will be responsible for any quality problem of it.

Our High qualified and responsible customer service team is waiting to hear from you and answer any of your questions **24/7**.

We are happy to receive your message about the problems you met so that we can help you to get out of the trouble. We are even happier to hear your praise about our wonderful projector and to see the happy moments our projector have brought to your life!

**The fastest and most efficient way to contact us?**

Method 1- Via email:

📧 [Support@jimveo.com](mailto:Support@jimveo.com)

Method 2:

Your Orders > The order has a problem > Choose a topic from list displayed > Select Contact seller

Please come. Please~~~



## PACKING LIST

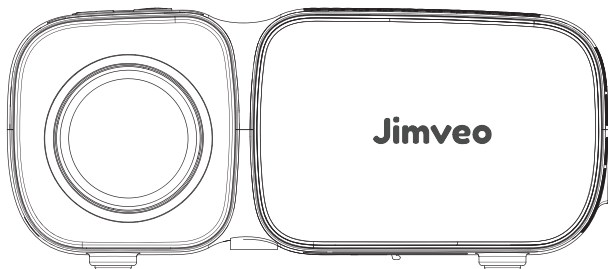

C11



Remote



User Manual



HD Cable

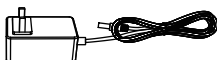

Power Cable

## NOTICE

Recommended

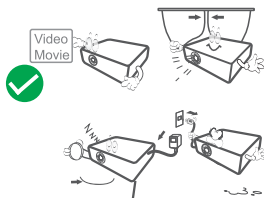

Not Recommended

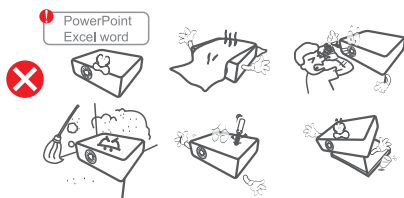

## FUNCTION OVERVIEW

### • Projector

#### Top View

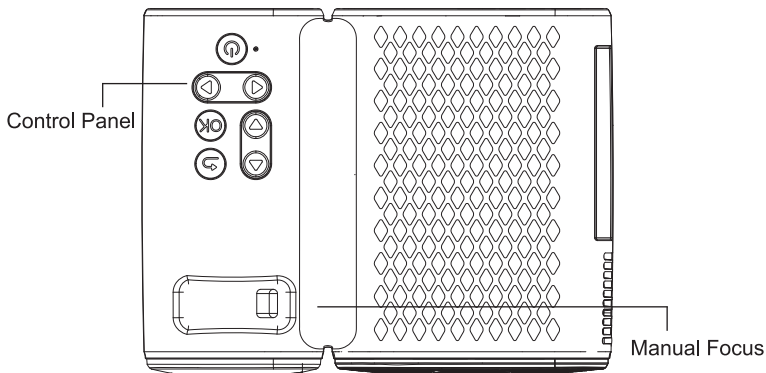

### Control Panel

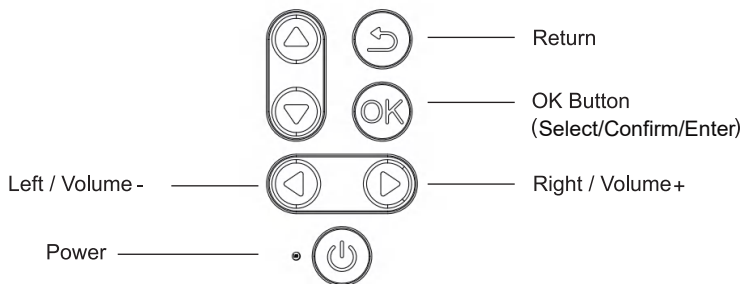



• **Bottom View**

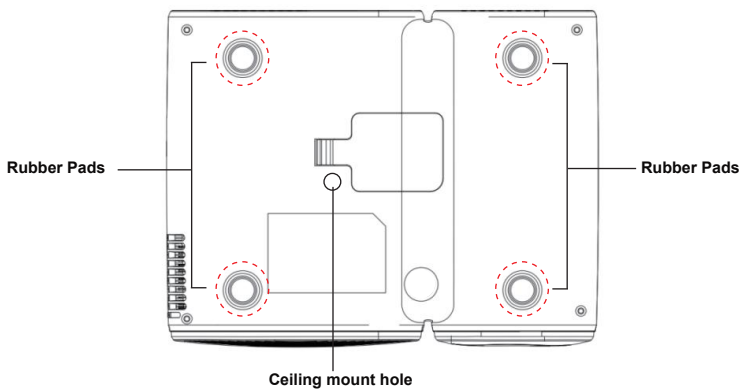

• **Front View**

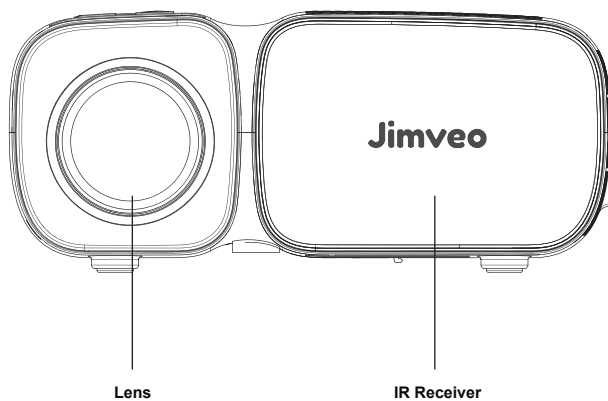

• Rear View

Power  
Cable Socket

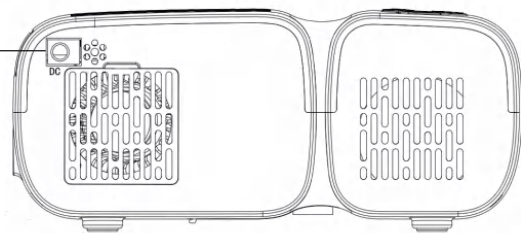

• Side View

A Left Side

HD Input    USB    AV Input    Headphone  
Output ( 3.5mm )

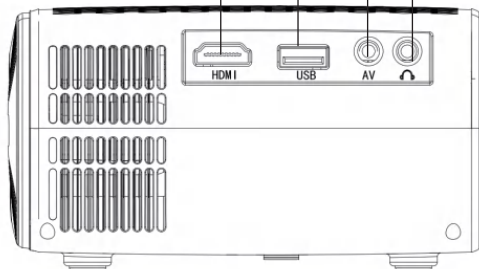

B Right Side

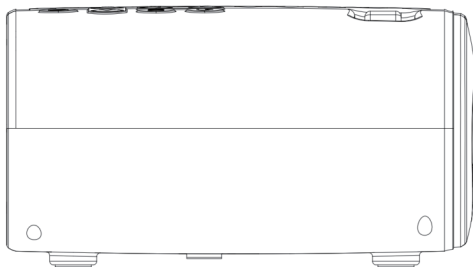

## • Remote Control

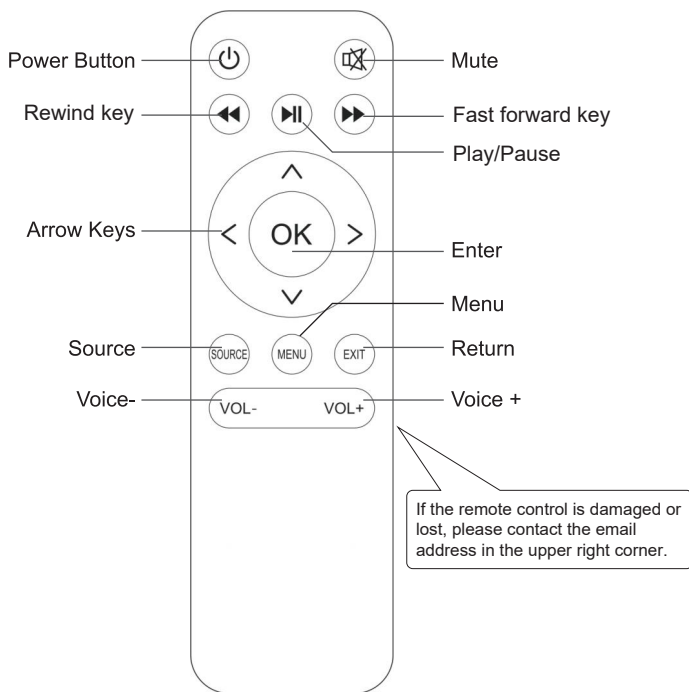

Note: Battery is not included

## Installation of the remote control

1. Install 2 pieces of AAA batteries into the remote before using it. Do not combine new batteries with old ones in a remote controller, which can cause operation failure due to insufficient power supply.

2. When using the remote controller, please make sure that the signal transmitter of the remote controller aims at the infrared signal receiver of the projector.

## QUICK START

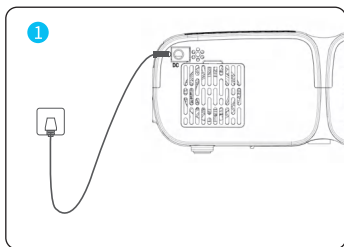

1. Plug the power cord into an outlet.

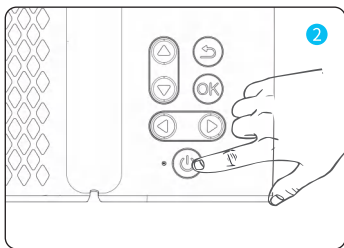

2. Press the power button to turn on the projector.

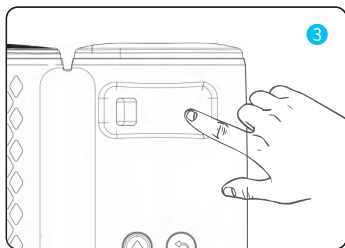

3. Adjust the focus ring to get the best image performance.

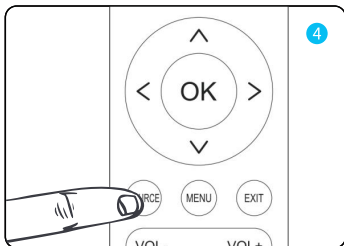

4. Press the "Source" button on the remote, select the correct input source to project your device.

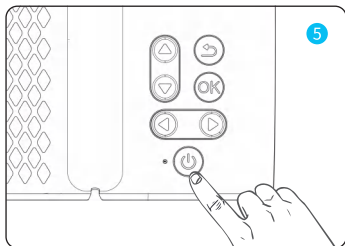

5. Press the power button twice to turn off the projector.

## Input Source

The projector will go to the USB Input Source interface by default when it is powered on. If you see “No Signal” on the screen, please confirm the projector's input source. And please select the according input sources when you are connecting it to different devices.

### USB Connection

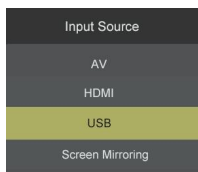
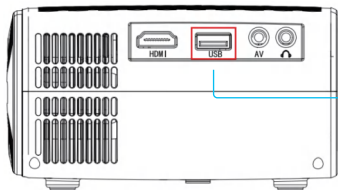

### HDMI Connection

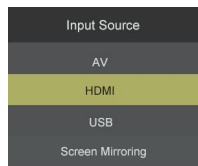
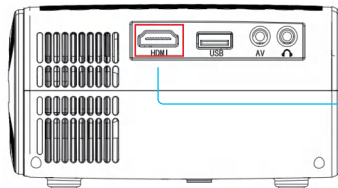

### Speaker Connection

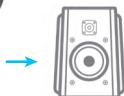
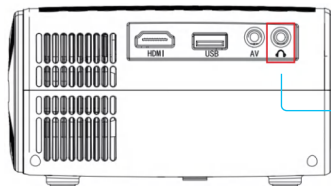

## DVD Connection

### • Method 1: Use the 3-in -1 AV cable

- 1) Turn on your DVD player and the projector;
- 2) Connect the colorful female connectors to your DVD player's RCA cable with the 3-in-1 AV cable (not included in the package);
- 3) Connect the black connector to the AV port of the projector, enter the home page to select [ AV ] as the signal source.

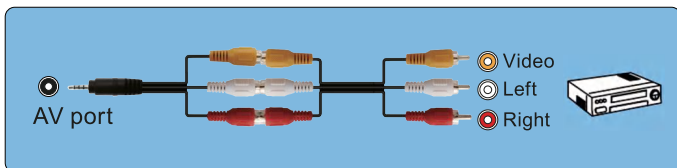
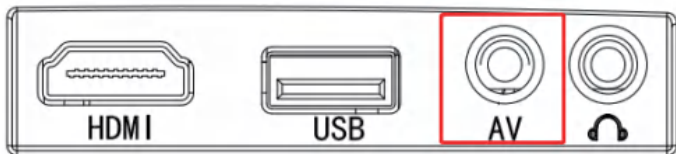

### • Method 2: Use the HDMI cable

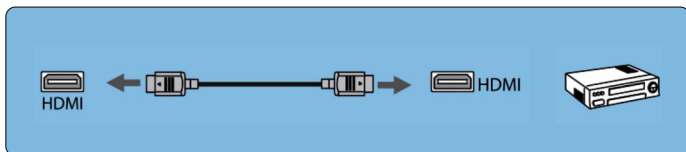
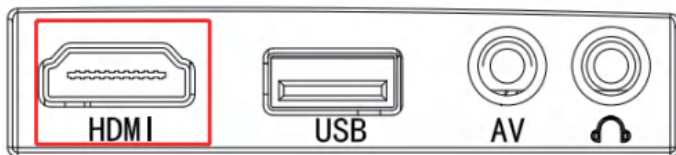

## Menu and Setting

### 1.Home Page

The home page of the projector is as follows:

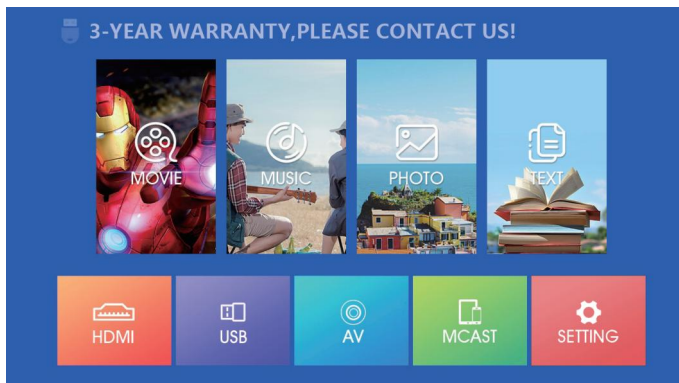

Please note that the default input source of the home page is USB. If it appears "No Signal" when you turn on the projector, please do not worry. Press the  button on the remote and choose "USB", you will go back to the home page.

### 2. Playing files via USB

Insert the USB flash drive into the USB port of the projector, select input source to "USB", you will go to the home page. Here you can choose to read the corresponding files from the USB drive. For example, if you want to play a video, select "Video" in the home page and choose the video file you want, press OK button on the remote to play it.

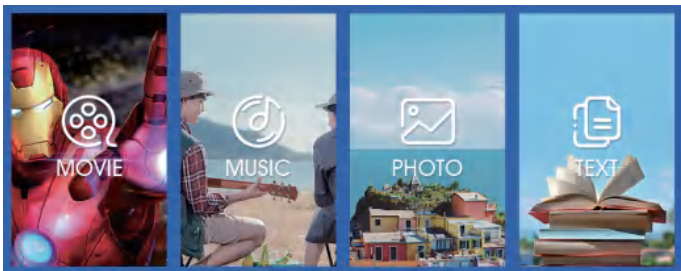

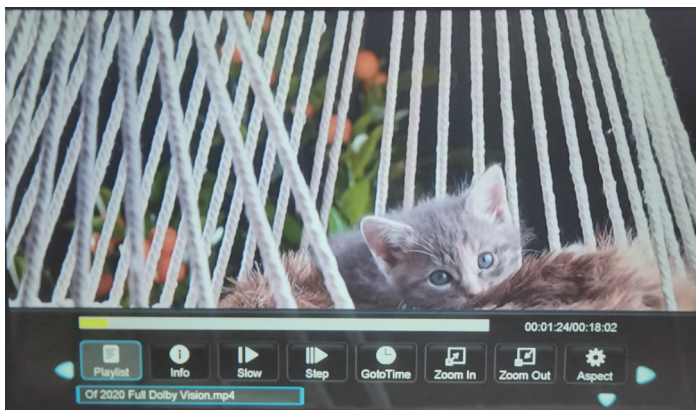

Press the [OK] button to see the many setting options under the video and picture. Please see details below:

Option	Description
Play/Pause	To play and pause the video
FB	Fast back 2/4/8/16/32 times
FF	Fast forward 2/4/8/16/32 times
Prev	Go to the previous video/picture
Next	Go to the next video/picture
Stop	Stop playing the video
Repeat	Repeat All/Repeat None/Repeat One
Set A/Set B	Intercept a segment of the video
Playlist	The playlist of all the videos in the USB
Info	The resolution and size information of the video
Stow	Slow play 2/4/8/16/32 times
Step	Fast play 2/4/8/16/32 times
GotoTime	Go to a desired time of the video
Zoom In	Zoom in the picture 2/4/8 times
Zoom Out	Zoom out the picture 2/4/8 times
Aspect	16:9/4:3



### 3. Setting of the Projector

Press the [Menu] button on the remote or choose [Setting] on the home page, you will go to the projector's setting page, where you can see four menu options: PICTURE, SOUND, TIME, OPTION

#### PICTURE Menu

PICTURE 	Picture Mode	Mild
	Contrast	45
	Brightness	45
	Color	45
	Sharpness	50
	Color Temperature	Medium
	Projection Direction	Front Table

Item	Options	Functions
Picture Mode	Standard/Dynamic/Mild/User	Set the picture mode
Color Temperature	Cool/Medium/Warm	Set the color temperature
Projection Direction	Front Table/Rear Table/ Front Ceiling/Rear Ceiling	Set the projection direction

#### SOUND Menu

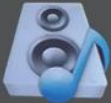
SOUND 	Sound Mode	Movie
	Treble	60
	Bass	80
	Balance	0

Item	Options	Functions
Sound Mode	Standard/Movie/Music/Sports/Use	Set sound mode
Balance	±50	Set sound balance

## TIME Menu

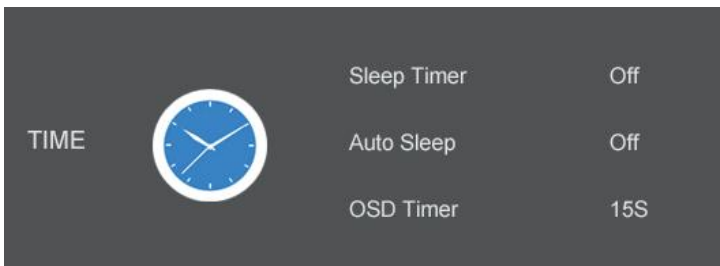

Item	Options	Functions
Sleep Timer	Off/10-240 minute	Set time to shut down the projector
Auto Sleep	On/off	Turn on/off auto sleep mode
OSD Timer	Never/5-30S	Set OSD time

## OPTION Menu

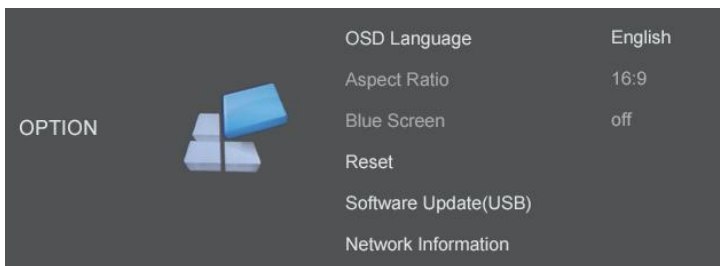

Item	Options	Functions
OSD Language	English/Japanese/ France/Spanish	Set languages
Aspect Ratio	16:9 /4:3	Available when playing videos via USB
Blue Screen	On/Off	Turn On/Off blue screen mode
Reset	Restore Factory Default	
Software Updates(USB)	If there are new version software, you can put the file in USB and update it here.	
Network Information	Network and Edition information of the projector	

## Wireless Projection with Phones and Laptops

Warming Tips:

- ① The fluency of screen mirroring with wireless connection will be affected by the network environment. A bandwidth of 100Mbit or more is recommended when using screen mirroring.
- ② Make sure your mobile device is close to the projector when using wireless connection. A distance within 1 meter is recommended.
- ③ Some mobile devices may not Support screen mirroring due to the compatibility.
- ④ Any questions, please feel free to email Jimveo via:  
**EU:Support@jimveo.com**

### ※ Wireless Projection with iOS Devices

#### Step 1: Connect the projector to your Router's wifi

- ① Click MCAST on the home page.  
Or press the [Source] button and select [Screen Mirroring] as the input source.
- ② Choose [WiFi Connection].
- ③ Select your router's WiFi from the list, enter the password, and press "Enter" to connect.
- ④ When the network is connected successfully, go to the [Wireless Connection with iOS] page.

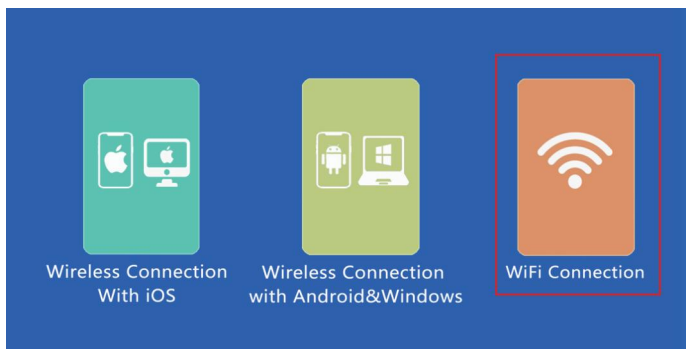
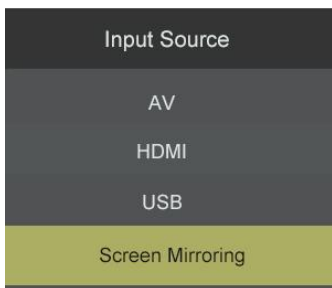





Wireless Connection  
With iOS



Wireless Connection  
with Android & Windows



WiFi Connection

## Wireless Screen Mirroring with iOS Devices

### Step 1: Connect the Projector to your Router's WiFi

Home Page → MCAST → WiFi Connection → Turn On → Search for WiFi → Choose your router's WiFi → Enter password to connect

### Step 2: Connect your device to the projector

For iPhone/iPad:

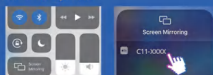

- ① Connect your iOS device to your router's WiFi.
- ② Tap the [Screen Mirroring] on your phone.
- ③ Search for devices, select the receiver [C11-XXXX] to connect and start wireless projection



Instructive videos are prepared for you. Scan the code to watch them, or contact us via:

 Support@jimveo.com

For Macbook:



- ① Connect your Macbook to your router's WiFi.
- ② Click Apple logo on top left → System Preference → Sharing → Airplay Display
- ③ Select [C11-XXXX] to connect and start wireless projection.

## Step 2: Connect your iOS device to the projector

### For iPhone/iPad:

- ① Turn WIFI on, connect your phone with router's WIFI.
- ② On your iOS device, open Control Center and tap [Screen Mirroring].
- ③ The phone will automatically scan for devices that can be mirrored on.
- ④ Select [C11-XXXX] from the list to connect your phone to the projector and start wireless projection.

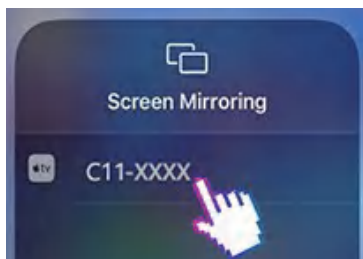

### For Macbook:

- ① Connect your Macbook to your router's WiFi.
- ② Click Apple logo on top left → System Preference → Sharing → Airplay Display
- ③ Select [C11-XXXX] to connect and start wireless projection.

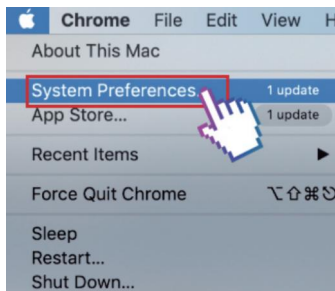
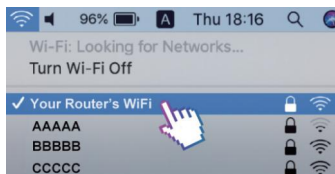

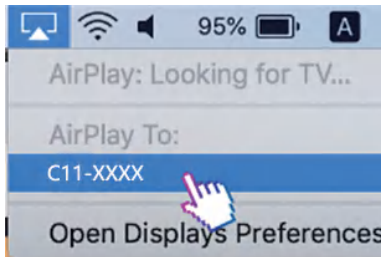
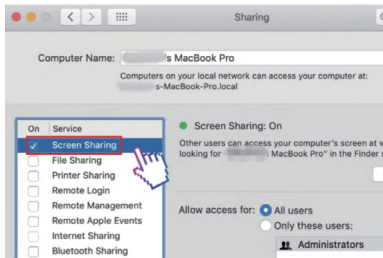
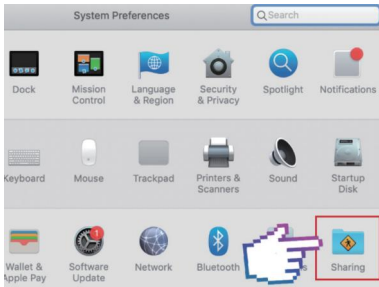

Any buyer with any questions who comes to email us will have our promise to get a satisfactory solution + an Extra 6 Month Warranty to thanks for your Support!

**EU:Support@jimveo.com**

## ※ Wireless Projection with Android&Windows

**Step 1: Go to the projector's [Wireless Connection with Android&Windows] page**

Press the [Source] button, select [Screen Mirroring] as input source. Choose [Wireless Connection with Android&Windows]

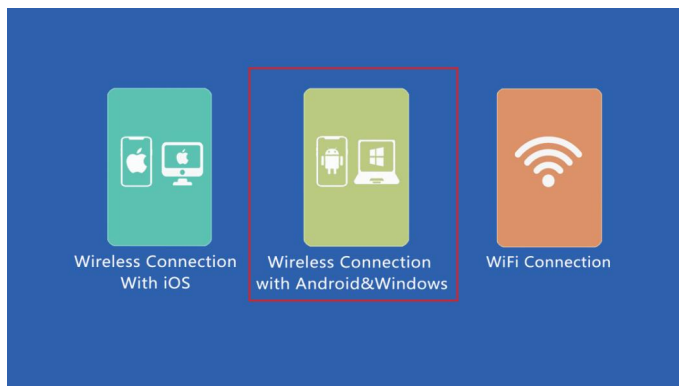
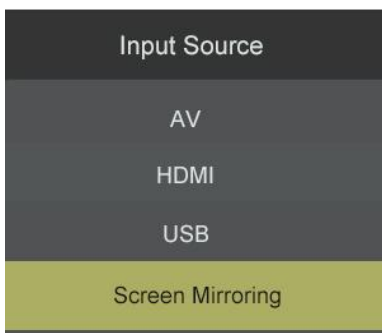



## Step 2: Connect your Android and Wins device to the projector

### For Android Phones:

- ① Connect your Android device to your router's WiFi.
- ② Tap the [Wireless Projection] or [Screen Mirroring] function on your phone.
- ③ Select the receiver [C11-XXXX] to connect and start wireless projection

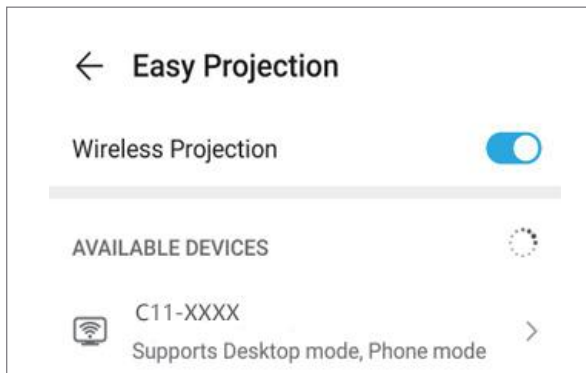
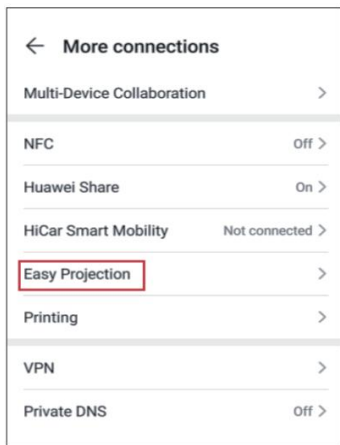
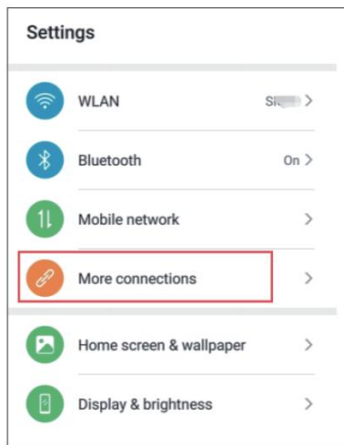

### For Wins Laptops:

- ① Connect your Win10 to your router's WiFi.
- ② Press Windows logo key [Win+K] on your keyboard
- ③ Select [C11-XXXX] to connect and start wireless projection.

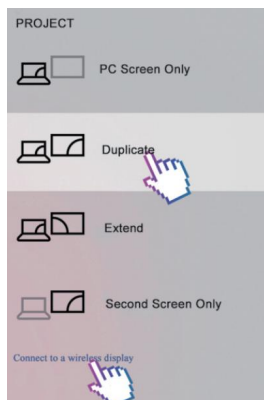

## Installation

### 1. Installation Method

The projector Support front and rear projection, it can be table mounted and ceiling mounted.

In the home page, go to [Setting]---[Picture]---[Projection Direction]. Choose your desired projection mode. There are four modes here: Front Table/Rear Table/ Front Ceiling/Rear Ceiling.

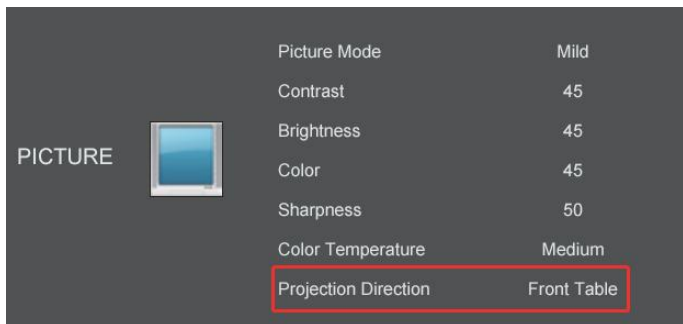

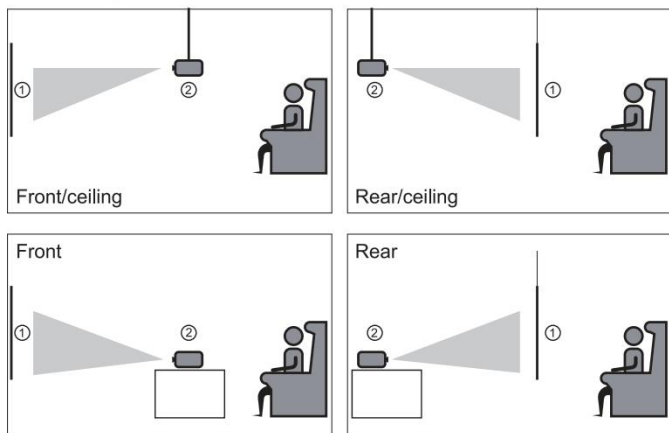

Please keep the projector at a height where its lens is axial symmetry to the screen.

\*Any buyer with any questions who comes to contact us will have our promise to get a satisfactory solution + an Extra 6 Month Warranty to thanks for your Support!

**EU:Support@jimveo.com**

**• Mount Ceiling Method:**

Please note that our projector only Support the one-hole ceiling mount.

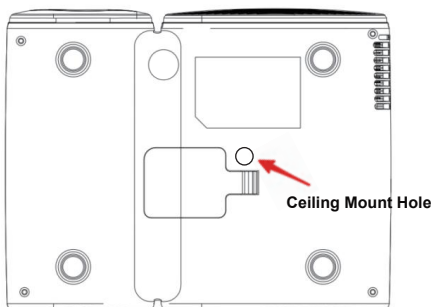

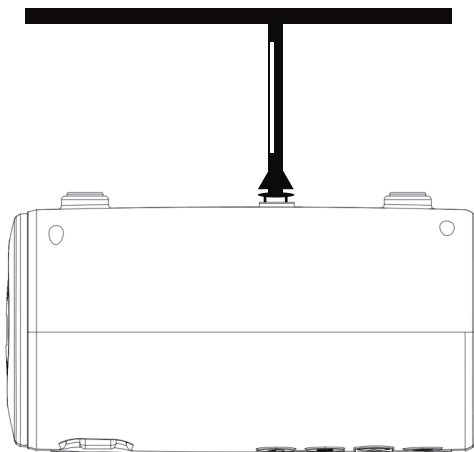

## 2. Projection Distance and Size

Please follow the data in chart below, to adjust the image size and the distance.

Projection Size	Projection Distance
40 Inch	3.67 FT
60 Inch	5.4 FT
80 Inch	7.16 FT
100 Inch	8.9 FT
120 Inch	10.63 FT

Please note :

1. The best image quality would be achieved with a projection distance of 6.5-8.5ft. A larger screen size would affect the image quality in a certain degree.
2. The image size depends on the distance between projector and screen, there may be 3% deviation among above listed data. Different settings cause various distances.

## SPECIFICATION

<b>MODEL: C11</b>	
Display	LCD
Installation Type	Front Table/Rear Table/ Front Ceiling/Rear Ceiling
Focus	Manual
Speaker	4W
Unit Dimension	165*128*66mm
Picture Format Supported	JPEG/PNG/BMP
Video Format Supported	MPEG1/MPEG2/MPEG4/H.263/H.264/AVS/ VC1/MJPEG/RV30/RV40/HEVC
Mounting Screw	1/4"
Light Source	LED
Input Signal	480P, 576i, 576P, 720i, 720P, 1080i, 1080P
Aspect Ratio	16:9, 4:3
Power Supply	AC 100-240V, 50/60Hz
Unit Net Weight	1.41kg
Audio Format Supported	MPEG1/MPEG2/LPCM/MP3/WMA2/AAC/WAV
Ports	USB*1/HDMI*1/AV*1/Headphone*1

\*Any buyer with any questions who comes to contact us will have our promise to get a satisfactory solution + an Extra 6 Month Warranty to thanks for your Support!

**EU:Support@jimveo.com**

If you don't receive a reply in 48h, it may be that our emails are folded to your spam mailbox, please check your spam mailbox or send us an email again.Thanks!

